



LIFTING GEAR HIRE CORPORATION

PHONE: 800-878-7305 FAX: 708-430-3536

www.lgh-usa.com

4 - 8 TON BEAM TROLLEY

JD NEUHAUS (PUSH / AIR / GEAR)

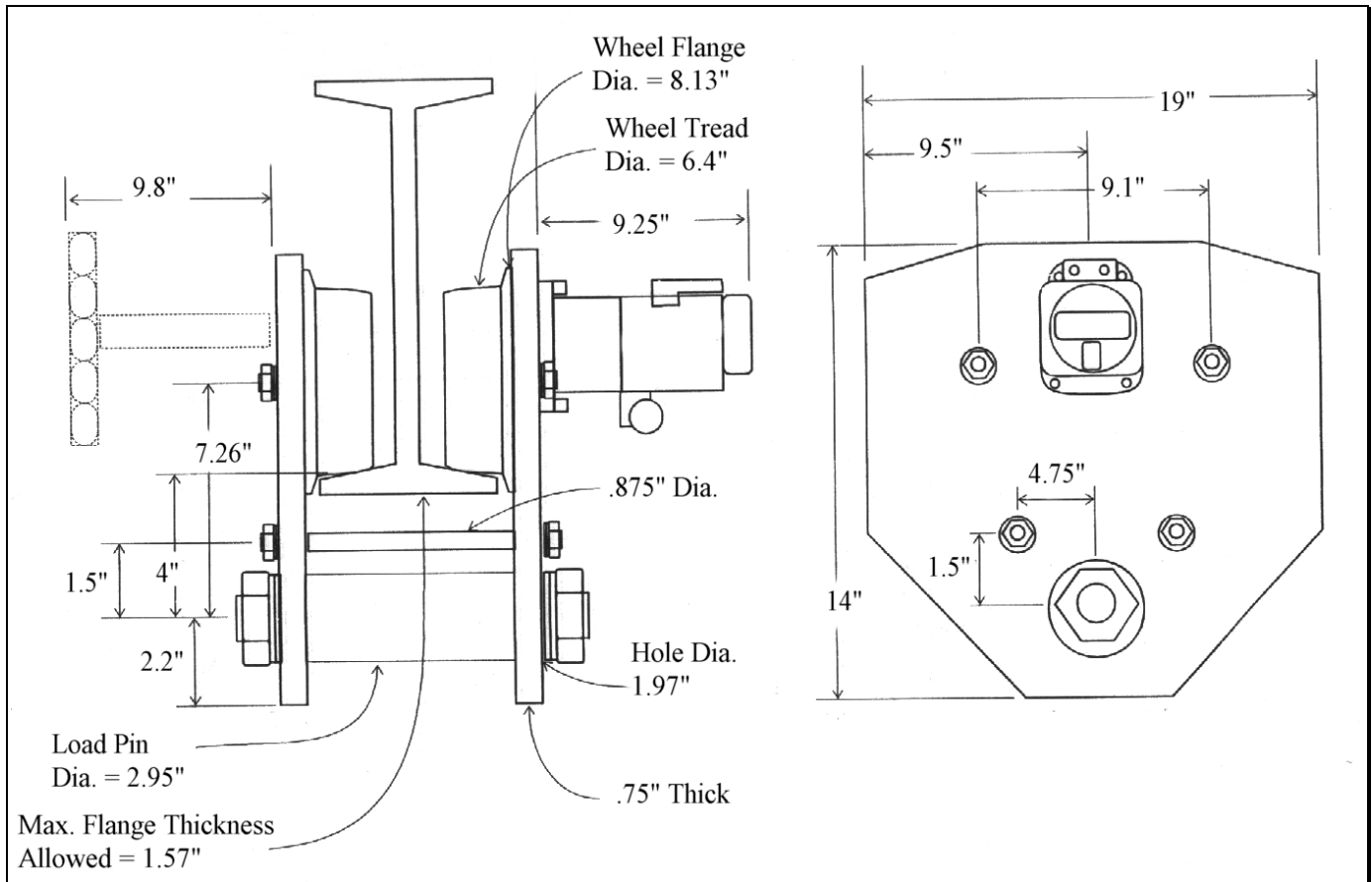

BEAM TROLLEY SPECIFICATIONS

Maximum Capacity	Flange Sizes (Min - Max)	Weight (lbs)	Traveling Speed	Air Consumption
16,000 lbs.	4.92" - 7.40"	264 lbs (push)	40 fpm	28.35 cfm
	7.48" - 9.68"	288 lbs (air)		
	9.72" - 12.2"	288 lbs (gear)		



LIFTING GEAR HIRE CORPORATION

PHONE: 800-878-7305 | FAX:708-430-3536 | www.lgh-usa.com

Trolley Installation (3T and up):

Trolleys 3T and larger are equipped with a solid load suspension pin to allow for lug or fixed mounting of the air hoist. Flange width for these trolleys are adjusted using spacers which can be moved between the inside and outside of each trolley plate. To keep the suspension pin centered the same spacer arrangement should be used on both ends of the pin.

Acceptable wheel flange clearance is between 2.0 to 3.0 per side. If the trolley is equipped with an anti-tipping device, the anti-tipping wheel should have roughly a 1.0mm clearance to the bottom of the beam.

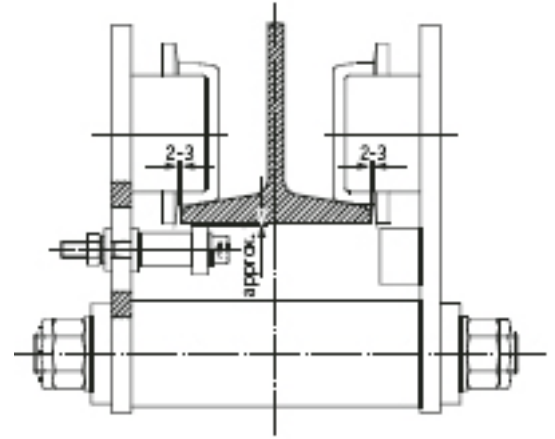

High Volume Chain Containers:

Improper installation of chain containers may result in serious danger including property damage, personal injury, or death. While the chain container will almost always arrive pre-installed to hoist; high volume chain containers used in long lift applications must also be installed with additional support connected to the existing structure.

Hook Mount hoists:

High capacity chain containers used in hook mount applications must be secured to the existing structure utilizing the steel connecting tabs welded to the outside surface of the container. This connection must be approved by a suitable professional in conjunction with the capabilities of the load bearing structure.

Trolley Applications:

High capacity chain containers used in trolley applications are equipped with either additional support brackets or an additional chain container suspension trolley.

NOTE: Please contact an LGH representative if you are uncertain whether your application requires chain container support.

