

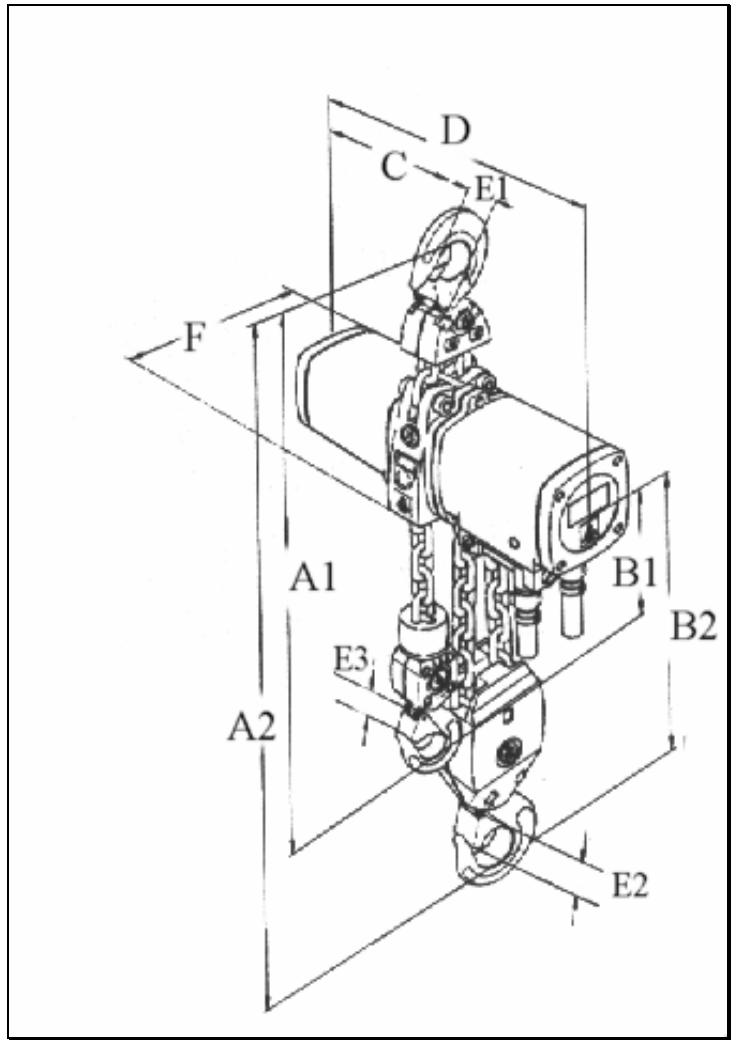

**LIFTING GEAR HIRE CORPORATION**

**PHONE: 800-878-7305**  
**FAX: 708-430-3536**  
**www.lgh-usa.com**

**6 / 12 TON**  
**AIR CHAIN**  
**HOIST**  
**J.D. NEUHAUS**  
**B 612PL**



**HOIST DIMENSIONS (in.)**

A1	A2	B1	B2	C	D	E1	E2	E3	F	No. of load chain / Size
36.2"	39.3"	18.2"	21.3"	13"	25"	1.7"	1.7"	1.6"	9.1"	1 or 2 / 16 X 45 mm

**HOIST SPECIFICATIONS**

Rated Load (ton)	Weight with (10' h.o.l.)	Minimum Distance Between Hooks (in.)
6 or 12	322# ( 3.90 lbs per extra foot h.o.l.)	30.4" / 32"

Air Consumption at rated Load (CFM)

Lifting	Lowering
81.5	NA

Lifting Speed

Rated Load	Without Load
3.6 / 1.8 fpm	9.5 / 4.3 fpm

Lowering Speed

Rated Load
13 / 6.3 fpm