

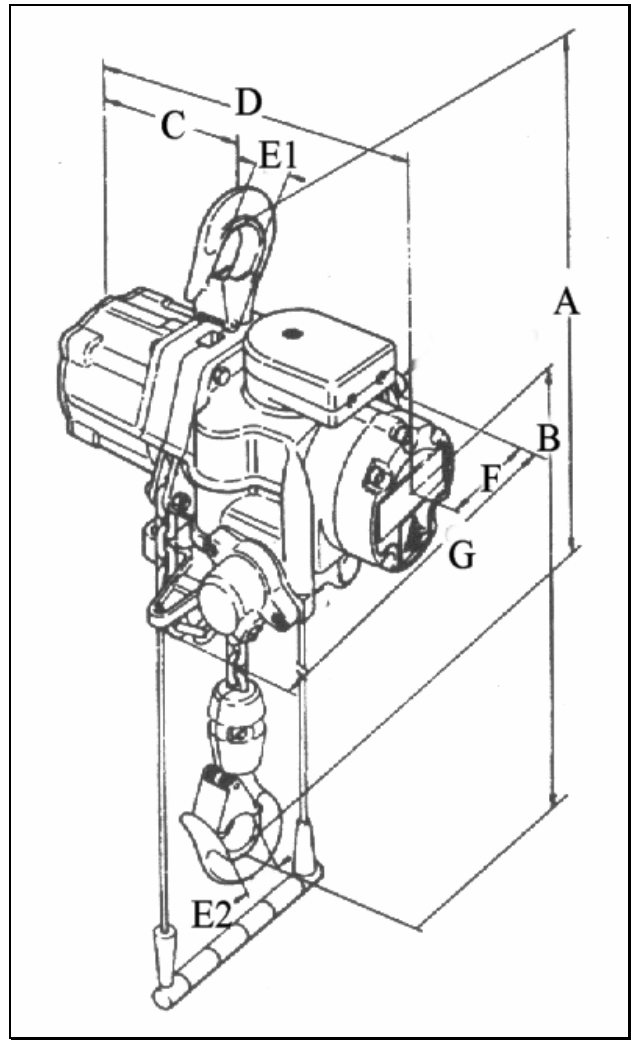

**LIFTING GEAR HIRE CORPORATION**

**PHONE: 800-878-7305**  
**FAX: 708-430-3536**  
**www.lgh-usa.com**

**6.3 TON**  
**AIR CHAIN**  
**HOIST**  
**J.D. NEUHAUS**  
**NEW 6.3TI**



**HOIST DIMENSIONS (in.)**

| A     | B     | C    | D     | E1   | E2   | F    | G    | No. of load chain / Size |
|-------|-------|------|-------|------|------|------|------|--------------------------|
| 26.5" | 17.9" | 9.2" | 19.0" | 1.6" | 1.6" | 6.1" | 9.2" | 2 / 13 X 36 mm           |

**HOIST SPECIFICATIONS**

| Rated Load<br>(lbs.) | Weight with<br>(10' h.o.l.)<br>242#<br>( 5.10 lbs per extra foot h.o.l.) | Minimum Distance<br>Between Hooks (in.)<br>26.5" |
|----------------------|--|--|
| 12,600               |  |  |

Air Consumption at rated Load (CFM)

| Lifting | Lowering |
|---------|----------|
| 113     | 134      |

Lifting Speed

| Rated Load | Without Load |
|------------|--------------|
| 8.2 fpm    | 16.4 fpm     |

Lowering Speed

| Rated Load |
|------------|
| 17.7 fpm   |