

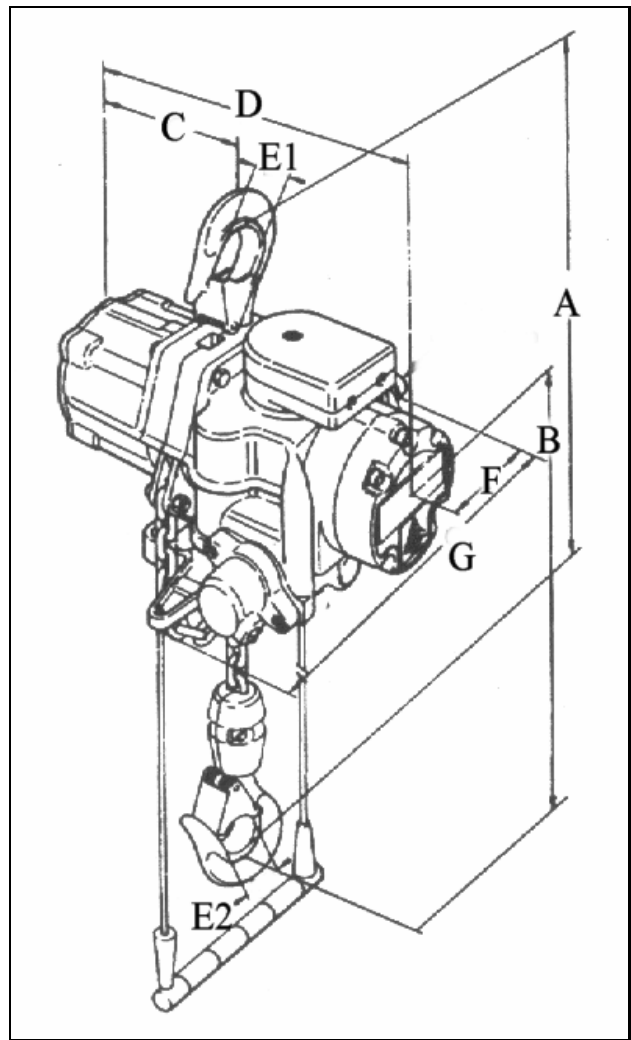

LIFTING GEAR HIRE CORPORATION

PHONE: 800-878-7305
FAX: 708-430-3536
www.lgh-usa.com

6 TON
AIR CHAIN
HOIST
J.D. NEUHAUS
6TI



HOIST DIMENSIONS (in.)

A	B	C	D	E1	E2	F	G	No. of load chain / Size
25.6"	16.9"	7.9"	18.9"	1.6"	1.6"	3.0"	10.8"	2 / 13 X 36 mm

HOIST SPECIFICATIONS

Rated Load (lbs.)	Weight with (10' h.o.l.)	Minimum Distance Between Hooks (in.)
12000	189.2#	25.6"
(5.10 lbs per extra foot h.o.l.)		

Air Consumption at rated Load (CFM)

Lifting	Lowering
85.0	110.0

Lifting Speed

Rated Load	Without Load
5.57 fpm	11.5 fpm

Lowering Speed

Rated Load
13.8 fpm