

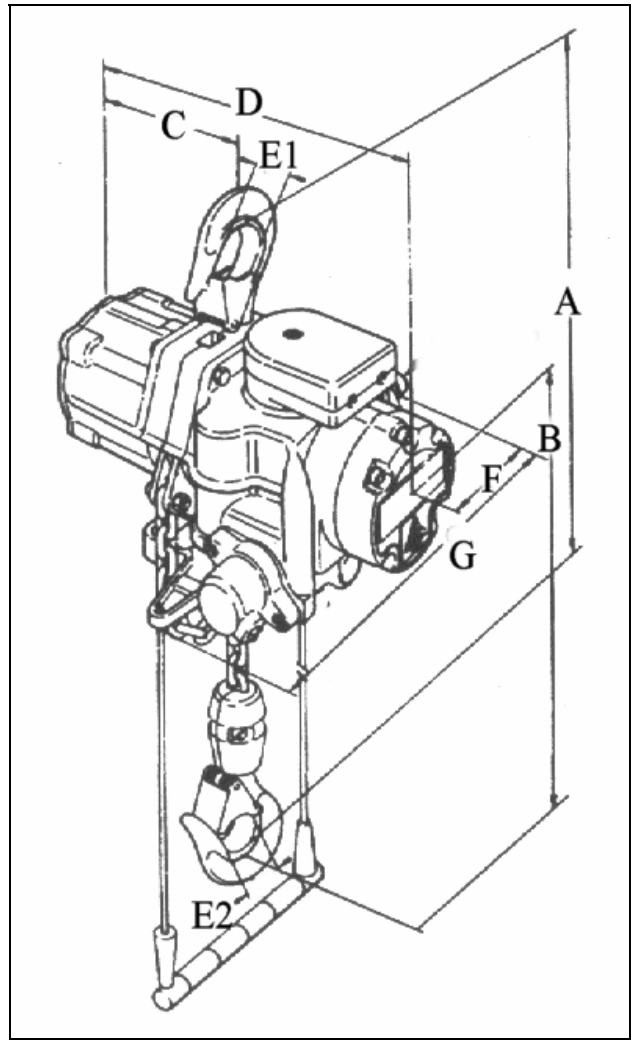

LIFTING GEAR HIRE CORPORATION

PHONE: 800-878-7305
FAX: 708-430-3536
www.lgh-usa.com

50 TON
AIR CHAIN
HOIST
J.D. NEUHAUS
50TI



HOIST DIMENSIONS (in.)

A	B	C	D	E1	E2	F	G	No. of load chain / Size
68.7"	46.8"	21.2"	44.3"	4.4"	4.4"	7.1"	19.3"	4 / 22 X 66 mm

HOIST SPECIFICATIONS

Rated Load (lbs.)	Weight with (10' h.o.l.)	Minimum Distance Between Hooks (in.)
100,000	2257# (29.0 lbs per extra foot h.o.l.)	68.7"

Air Consumption at rated Load (CFM)

Lifting	Lowering
390	496

Lifting Speed

Rated Load	Without Load
2.3 fpm	4.3 fpm

Lowering Speed

Rated Load
4.9 fpm