

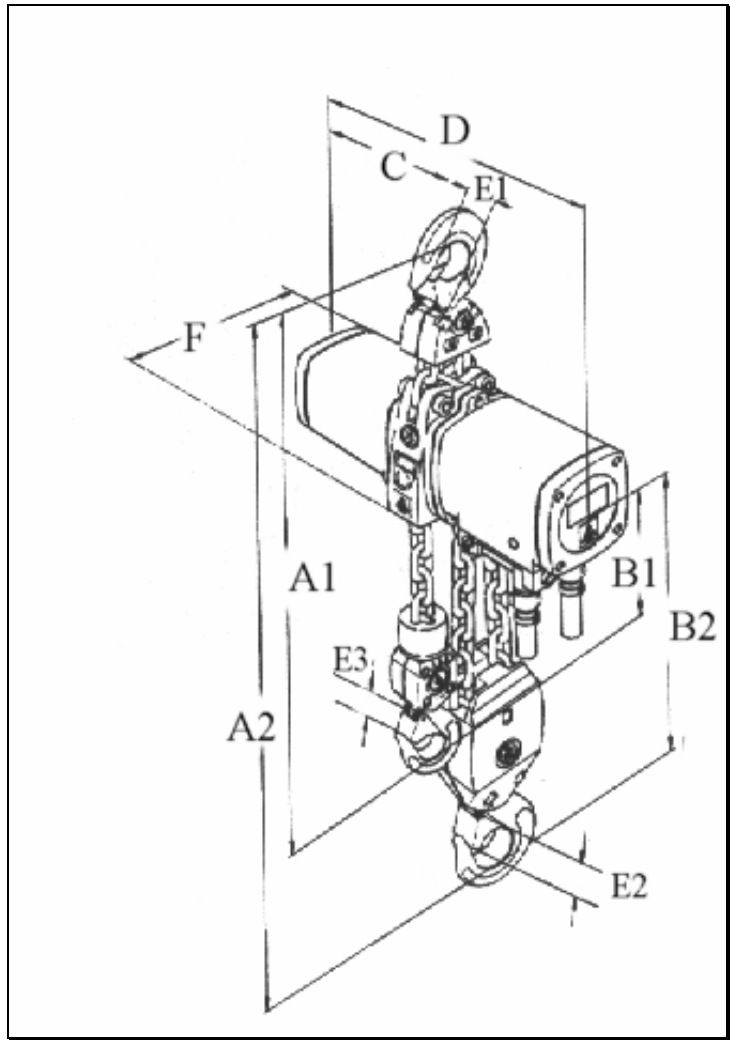

**LIFTING GEAR HIRE CORPORATION**

**PHONE: 800-878-7305**  
**FAX: 708-430-3536**  
**www.lgh-usa.com**

**4 / 8 TON**  
**AIR CHAIN**  
**HOIST**  
**J.D. NEUHAUS**  
**B 48PL**



**HOIST DIMENSIONS (in.)**

A1	A2	B1	B2	C	D	E1	E2	E3	F	No. of load chain / Size
30.4"	32.0"	16.5"	18"	11.3"	22.7"	1.6"	1.6"	1.2"	7.2"	1 or 2 / 13 X 36 mm

**HOIST SPECIFICATIONS**

Rated Load (ton)	Weight with (10' h.o.l.)	Minimum Distance Between Hooks (in.)
4 or 8	203# ( 2.55 lbs per extra foot h.o.l.)	30.4" / 32"

Air Consumption at rated Load (CFM)

Lifting	Lowering
81.5	NA

Lifting Speed

Rated Load	Without Load
5.5 / 2.7 fpm	13 / 6.5 fpm

Lowering Speed

Rated Load
19 / 9.5 fpm