



LIFTING GEAR HIRE CORPORATION

PHONE: 800-878-7305 FAX: 708-430-3536

www.lgh-usa.com

3 TON AIR CHAIN HOIST

INGERSOLL-RAND - LCA Model

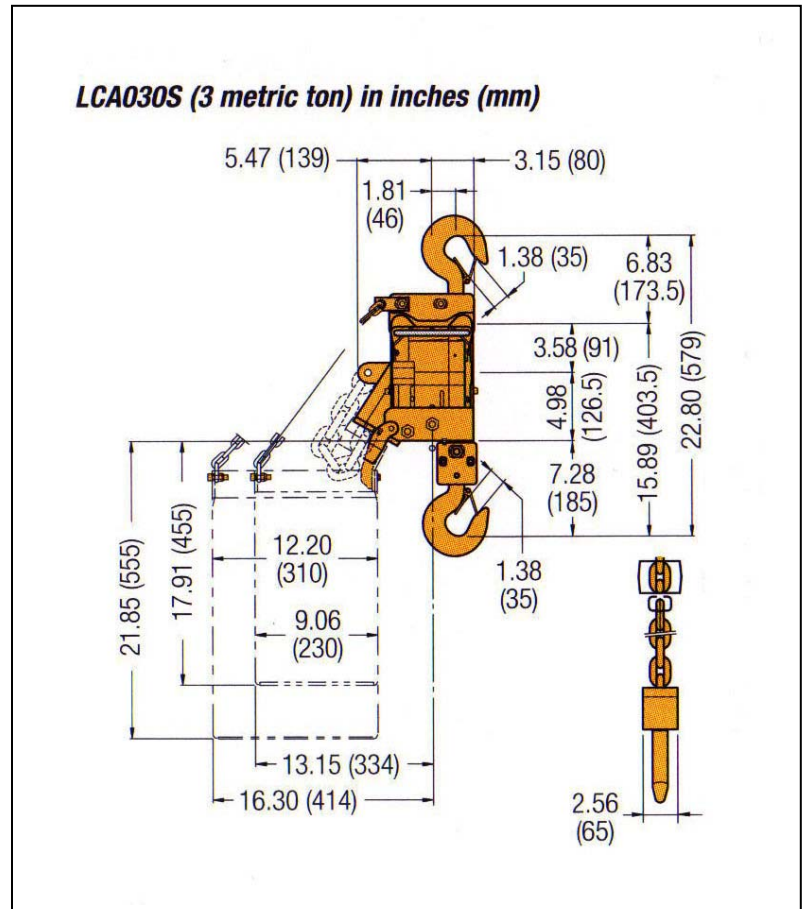
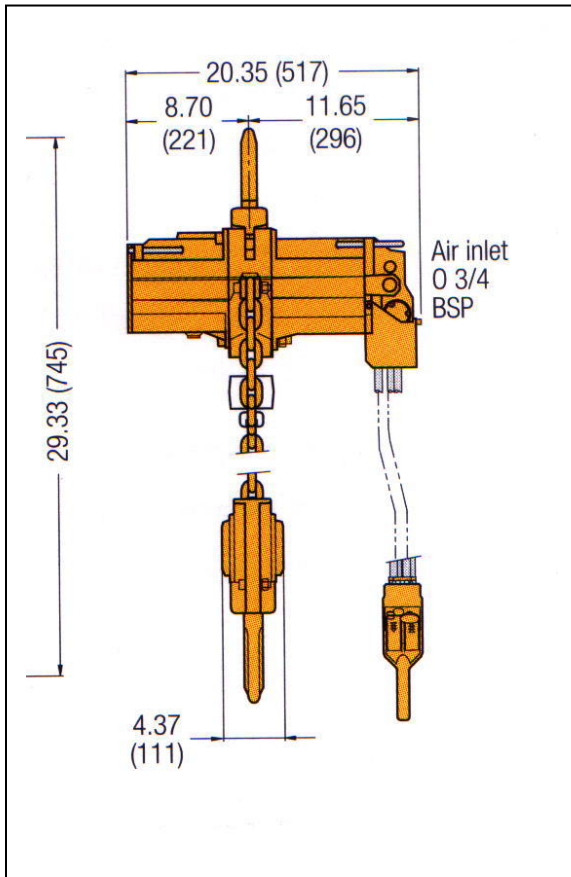

HOIST SPECIFICATIONS

Rated Load
(lbs.)
6,000

Weight with
(10' h.o.l.)
196#
(3.0 lbs. per extra foot h.o.l.)

Minimum Distance
Between Hooks (in.)
22.80"

No. of Load
Chain / Size
1 / 13 X 36 mm

Air Consumption at rated Load (CFM)
Average
124

Lifting Speed
Rated Load
10.5 fpm

Lowering Speed
Rated Load
23.0 fpm