

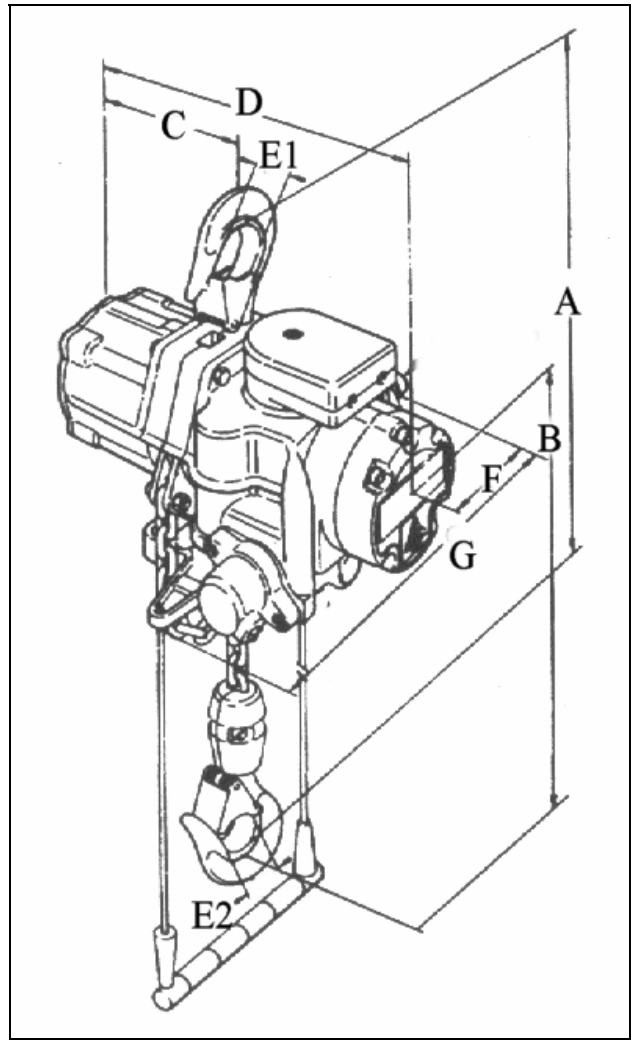

LIFTING GEAR HIRE CORPORATION

PHONE: 800-878-7305
FAX: 708-430-3536
www.lgh-usa.com

3.2 TON
AIR CHAIN
HOIST
J.D. NEUHAUS
NEW 3.2TI



HOIST DIMENSIONS (in.)

A	B	C	D	E1	E2	F	G	No. of load chain / Size
23.3"	14.7"	9.2"	19.0"	1.6"	1.2"	7.4"	9.2"	1 / 13 X 36 mm

HOIST SPECIFICATIONS

Rated Load (lbs.)	Weight with (10' h.o.l.)	Minimum Distance Between Hooks (in.)
6,400	189# (2.55 lbs. per extra foot h.o.l.)	23.3"

Air Consumption at rated Load (CFM)

Lifting	Lowering
113	134

Lifting Speed

Rated Load	Without Load
16.4 fpm	32.8 fpm

Lowering Speed

Rated Load
35.4 fpm