

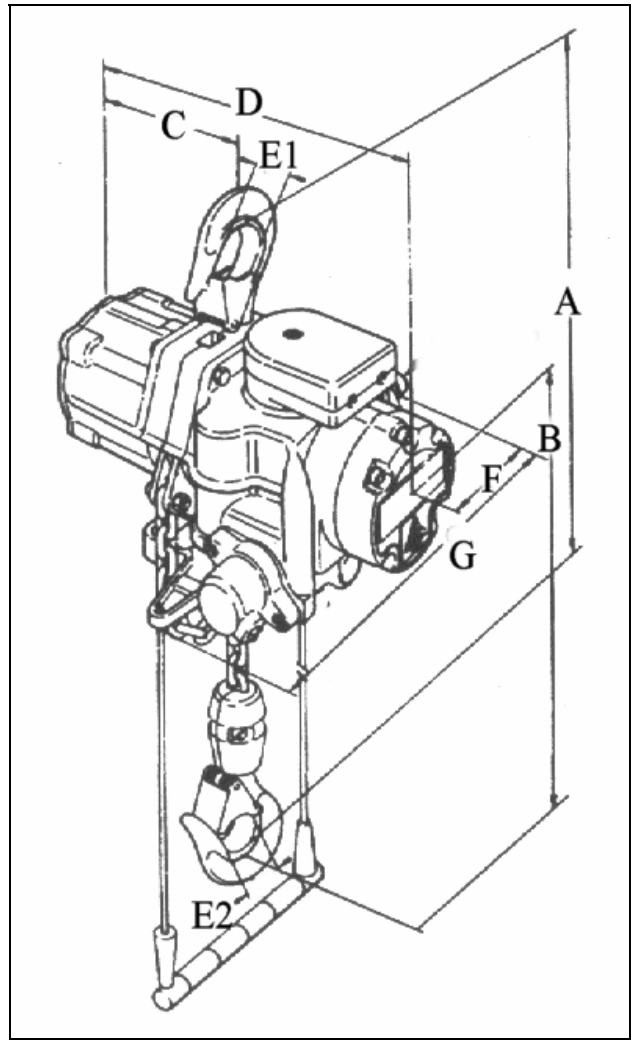

**LIFTING GEAR HIRE CORPORATION**

**PHONE: 800-878-7305**  
**FAX: 708-430-3536**  
**www.lgh-usa.com**

**3 TON**  
**AIR CHAIN**  
**HOIST**  
**J.D. NEUHAUS**  
**3TI**



**HOIST DIMENSIONS (in.)**

A	B	C	D	E1	E2	F	G	No. of load chain / Size
21.3"	12.6"	7.9"	18.9"	1.6"	1.2"	3.0"	10.8"	1 / 13 X 36 mm

**HOIST SPECIFICATIONS**

Rated Load (lbs.)	Weight with (10' h.o.l.)	Minimum Distance Between Hooks (in.)
6,000	147.4#	21.3"
( 2.55 lbs. per extra foot h.o.l.)		

Air Consumption at rated Load (CFM)

Lifting	Lowering
85.0	110.0

Lifting Speed

Rated Load	Without Load
11.45 fpm	22.9 fpm

Lowering Speed

Rated Load
27.9 fpm