



**LIFTING GEAR HIRE CORPORATION**

PHONE: 800-878-7305 FAX: 708-430-3536

www.lgh-usa.com

**2 TON AIR CHAIN HOIST**

HARRINGTON – TCR Model

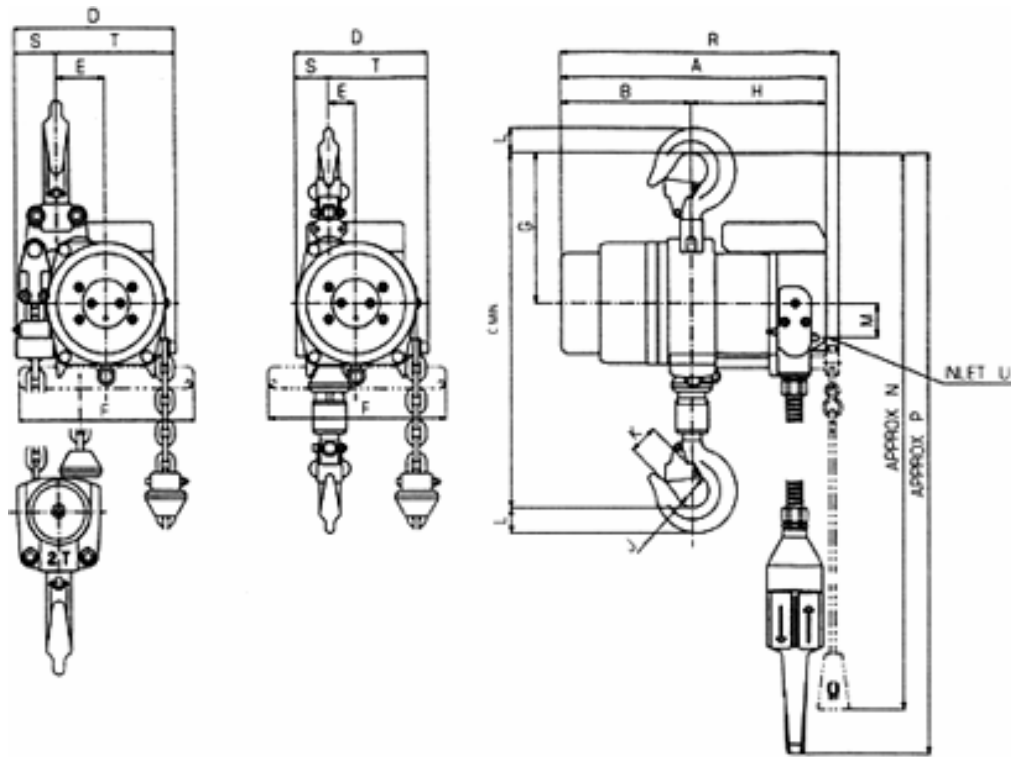

**HOIST DIMENSIONS (in.)**

A	B	C	D	E	F	G	H	J	K	L	M	N	P	R	S	T
12.5"	6.1"	19.9"	7.5"	2.3"	8.3"	8.0"	6.5"	1.8"	1.3"	1.5"	1.5"	6.2"	-	14.0"	1.5"	5.7"

**HOIST SPECIFICATIONS**

Rated Load lbs.)	Weight with (10' h.o.l.)	Minimum Distance Between Hooks (in.)	No. of load chain / Size
4,000	95# (1.5 lbs. per extra foot h.o.l.)	19.8"	2 / 7.1 X 21.0 mm

Air Consumption at rated Load (CFM)

Lifting	Lowering
53	60

Lifting Speed

Rated Load	Without Load
10.0 fpm	19.5 fpm

Lowering Speed

Rated Load
17.0 fpm