



**LIFTING GEAR HIRE CORPORATION**

PHONE: 800-878-7305 FAX: 708-430-3536

www.lgh-usa.com

**25 TON AIR CHAIN HOIST**

INGERSOLL-RAND HA2-025 “Hercu-link”

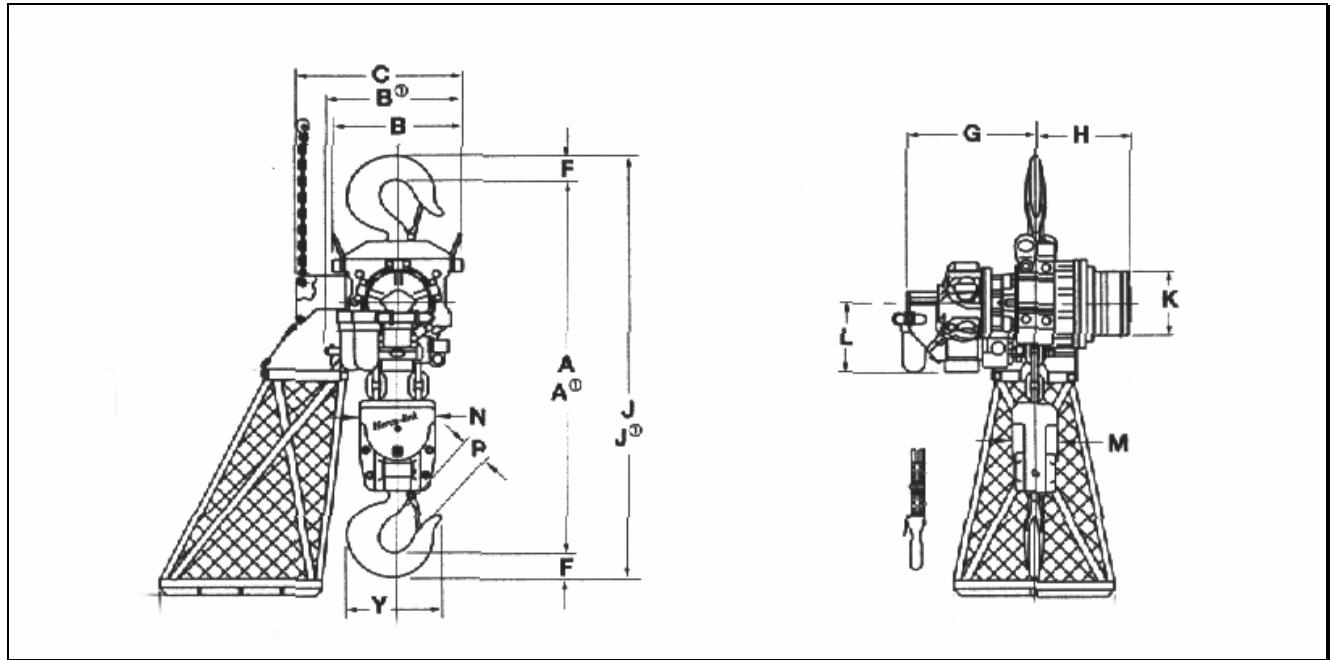

**HOIST DIMENSIONS (in.)**

<u>A</u>	<u>B</u>	<u>C</u>	<u>F</u>	<u>G</u>	<u>H</u>	<u>J</u>	<u>K</u>	<u>L</u>	<u>M</u>	<u>N</u>	<u>P</u>	<u>Y</u>
51.1"	21.3"	24.5"	3.62"	19.5"	14.3"	58.4"	9.6"	9.9"	6.9"	11.3"	3.25"	13.6"

**HOIST SPECIFICATIONS**

Rated Load (lbs.) 55,000	Weight with (10' h.o.l.) 1235# (15 lbs per extra foot h.o.l.)	Minimum Distance Between Hooks (in.) 51 1/8"	No. of Load Chain / Size 2 / 22 X 66 mm
--------------------------------	--	--	---

<u>Air Consumption at rated Load (CFM)</u>	
Lifting	Lowering
280	280

<u>Lifting Speed</u>
Rated Load
4 fpm

<u>Lowering Speed</u>
Rated Load
6 fpm