

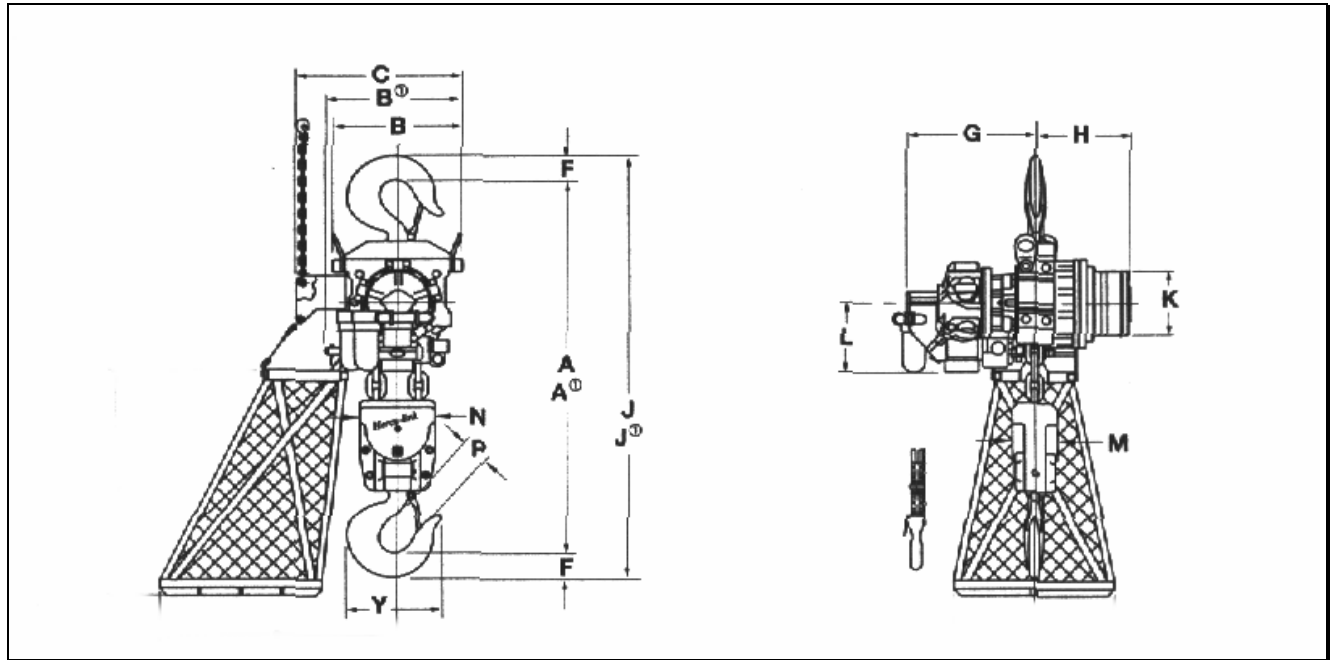

LIFTING GEAR HIRE CORPORATION
PHONE: 800-878-7305 FAX: 708-430-3536
www.lgh-usa.com
15 TON AIR CHAIN HOIST
INGERSOLL-RAND HA1-015 "Hercu-link"



HOIST DIMENSIONS (in.)

<u>A</u>	<u>B</u>	<u>C</u>	<u>F</u>	<u>G</u>	<u>H</u>	<u>J</u>	<u>K</u>	<u>L</u>	<u>M</u>	<u>N</u>	<u>P</u>	<u>Y</u>
41.8"	19.0"	-	3.0"	19.0"	14.9"	47.9"	7.8"	5.0"	5.2"	10.0"	3.38"	11.0"

HOIST SPECIFICATIONS

Rated Load (lbs.) 30,000	Weight with (10' h.o.l.) 875# (15 lbs per extra foot h.o.l.)	Minimum Distance Between Hooks (in.) 41.88"	No. of Load Chain / Size 23/ 16 X 36 mm
---------------------------------------	--	--	--

Air Consumption at rated Load (CFM)
 Average
 165

Lifting Speed
 Rated Load
 3.25 fpm

Lowering Speed
 Rated Load
 5 fpm