



LIFTING GEAR HIRE CORPORATION

PHONE: 800-878-7305 FAX: 708-430-3536

www.lgh-usa.com

12 TON AIR CHAIN HOIST

INGERSOLL-RAND - LCA Model

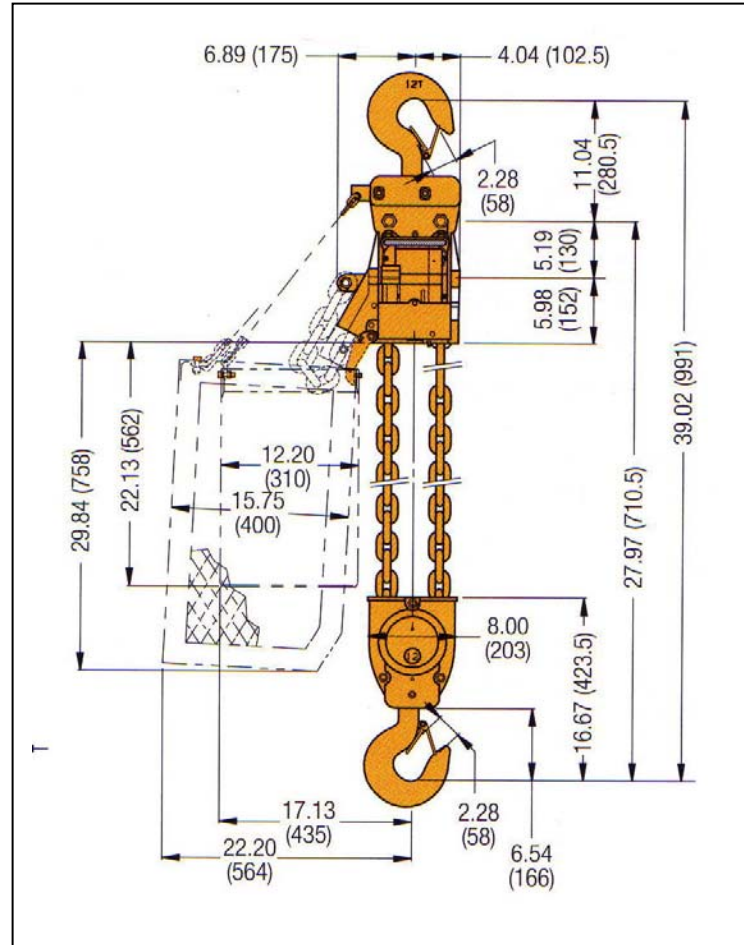
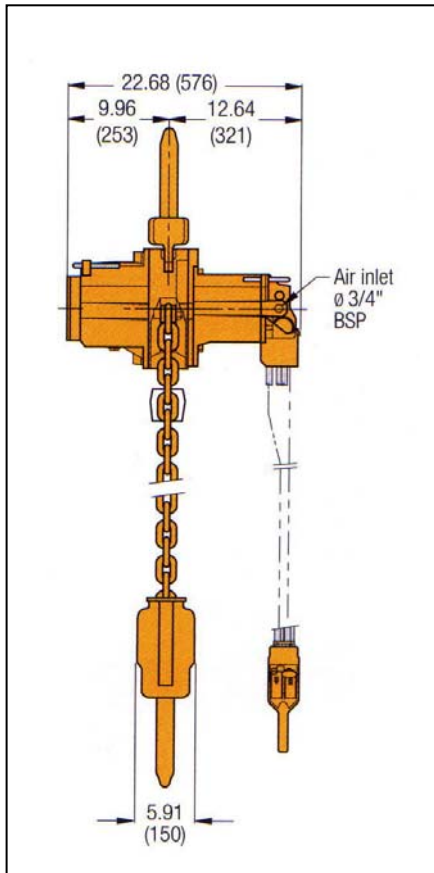

HOIST SPECIFICATIONS

Rated Load
(lbs.)
24,000

Weight with
(10' h.o.l.)
415#

Minimum Distance
Between Hooks (in.)
39.02"

No. of Load
Chain / Size
2 / 16 X 45 mm

(12.5 lbs. per extra foot h.o.l.)

Air Consumption at rated Load (CFM)
Average
124

Lifting Speed
Rated Load
2.9 fpm

Lowering Speed
Rated Load
4.9 fpm