

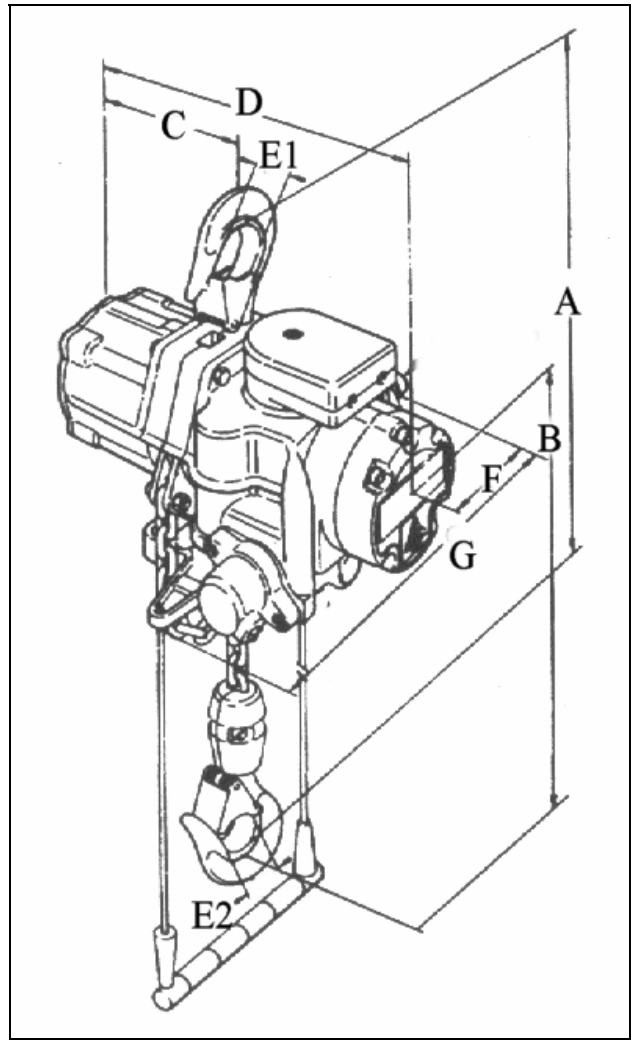

LIFTING GEAR HIRE CORPORATION

PHONE: 800-878-7305
FAX: 708-430-3536
www.lgh-usa.com

10 TON
AIR CHAIN
HOIST
J.D. NEUHAUS
NEW 10TI



HOIST DIMENSIONS (in.)

A	B	C	D	E1	E2	F	G	No. of load chain / Size
32.0"	21.6"	12.1"	22.6"	1.7"	1.7"	7.8"	12.0"	2 / 16 X 45 mm

HOIST SPECIFICATIONS

Rated Load (lbs.)	Weight with (10' h.o.l.)	Minimum Distance Between Hooks (in.)
20,000	343.0#	32"
(7.80 lbs per extra foot h.o.l.)		

<u>Air Consumption at rated Load (CFM)</u>	
Lifting	Lowering
113	134

<u>Lifting Speed</u>	
Rated Load	Without Load
5.24 fpm	10.5 fpm

<u>Lowering Speed</u>
Rated Load
11.2 fpm