

Barrier Grabs

Model BLG – Barrier Grab Specifications



Product Features:

- Special Auto-Latch mechanism makes operation virtually hands free.
- No need to attach and secure lifting chains or slings.
- Barriers suffer far less damage resulting in longer life and reduced cost.
- The grab moves barriers quicker and easier than manual methods, resulting in less man-hours.
- There is no need to drill holes in the barriers to accommodate chains or slings.
- Replaceable polyurethane lifting pads are designed for unpainted barriers.
- Replaceable steel 'Dog Point' lifting pads are designed for painted barriers (typical in coastal areas).
- Designed and manufactured to ASME standards.

Specifications		
Model Number	Rated Capacity (lbs.)	Weight (lbs.)
Polyurethane Lifting Pad		
74 - 4¼	8,500	450
74 - 7¼	14,500	505
Steel "Dog Point" Lifting Pads		
74 - 4¼ DP	8,500	450
74 - 7¼ DP	14,500	505

Green shading reflects rental inventory.

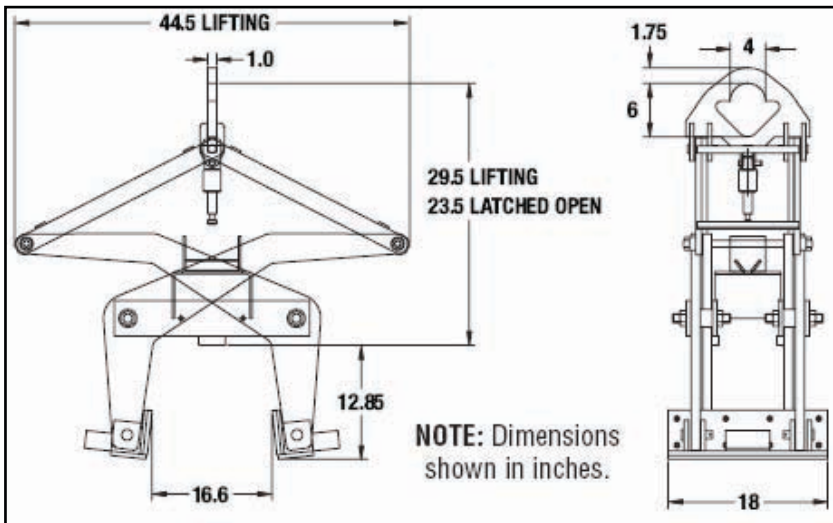

Model 74

